

Rotary Diaphragm Pump KPV08 Series KPV08A

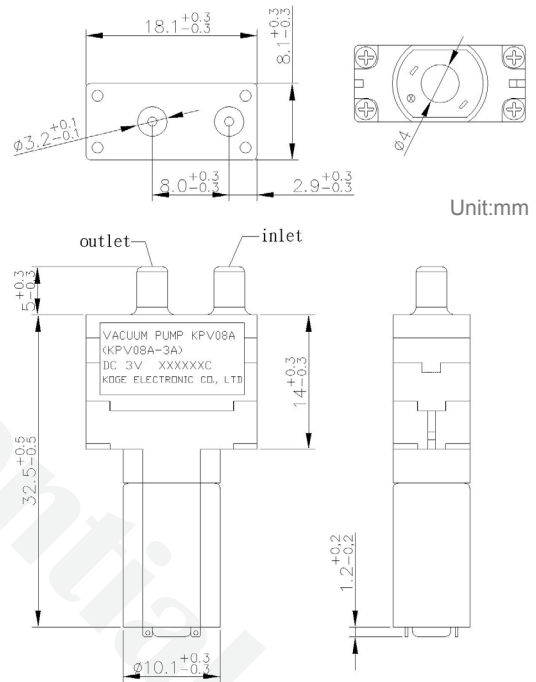

Concept

Piston pumps and plunger pumps are reciprocating positive displacement pumps that use a plunger or piston to move media through a cylindrical chamber.

They use a mechanism (typically rotational) to create a reciprocating motion along an axis, which then builds pressure in a cylinder or working barrel to force gas or fluid through the pump. The pressure in the chamber actuates the valves at both the suction and discharge points.

Specifically, air flow rate is proportional to motor speed, piston stroke, and piston diameter.

Features

- ▶ Compact size
- ▶ High level of gas tightness
- ▶ High performance

Application

- ▶ Medical instruments
- ▶ Medical consumer devices
- ▶ Industrial pressure and vacuum applications
- ▶ Combustion analyzers
- ▶ Portable analytical instruments
- ▶ Gas or Odor leak detectors

Model Key

Category	KOGE	Pump	Type	Pump Head Size	Series A~Z	Voltage	Series	Output
Diaphragm	K	P	V	08	A	3	A	KPV08A-3A

Specifications

Part Number	KPV08A-3A
Voltage	DC 3V
Operating Voltage	DC 2.2V~3.3V
Max. Flow	0.53 L/min
Max. Vacuum	-266mmHg
Max. Current	375mA
Life	5,000 cycles
Testing Cycle	On 15s;Off 5s @100CC Tank
Noise Level	< 75 dB

Materials

Nozzle	ABS
Valve	NBR
Diaphragm	EPDM
Motor	DC brush

Curve Graph

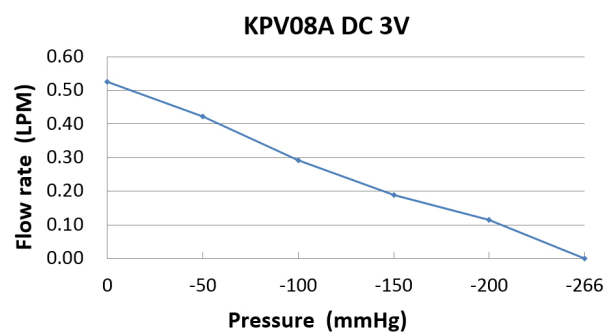

KOGE reserves the right to make technical changes without notice.